

serie
FGi

 **Morella Forni®**

**Forno ibrido legna e gas
+ piano riscaldato a gas**
**Four Hybride bois et gaz +
sole chauffée au gaz**



- Les fours FGi ont un fonctionnement hybride bois et gaz, ils ne peuvent être utilisés qu'à bois ou gaz seul ou combiné gaz + bois simultanément.
- Les fours de la série FGi sont équipés de deux brûleurs indépendants, un dédié à chauffage du dôme et un au chauffage de la table de cuisson.
- Les zones de combustion du bois et du brûleur à gaz sont séparées par des chenets métalliques.
- Les brûleurs dédiés au chauffage du sol confèrent une stabilité thermique à la base du four, pour rendre le processus de cuisson plus rapide et plus homogène.
- Le tiroir de chute et de collecte des cendres facilite les opérations de nettoyage, améliore la combustion du bois et conditions de cuisson hygiéniques.
- Double mode de fonctionnement : manuel - l'opérateur sélectionne la température maximale et régule manuellement l'intensité de la flamme du gaz au moyen du modulateur de flamme ; automatique (uniquement dans la version à écran tactile) : grâce au système de contrôle, la flamme est autoréglée et décroissante et augmenter l'intensité en fonction de la température réglée, économisant la consommation et simplifiant l'utilisation.

FORNO STATICO/FOUR STATIQUE

le finiture della linea/range finishes • FGi

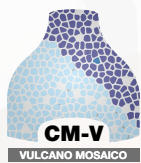
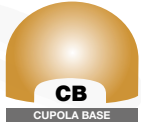
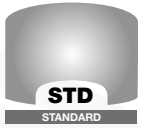

Mod./Ref.	Capacità pizze Ø 30 cm./Capacity pizzas Ø 30 cm.	Produzione oraria/Productivity per hour
FGi100	6 pizze	70 pizze / h
FGi110	7 pizze	90 pizze / h
FGi130	9 pizze	120 pizze / h
FGi150	14 pizze	150 pizze / h

Forno Mod./Oven Ref.	Potenzialità Legna/ Wood Potential	Potenzialità Gas/ Total gas potential	Consumo/Consumption		Attacchi Gas/ Gas fittings
			Metano/Methane (mc/h)	G.P.L./L.P.G. (Kg/h)	
FGi100	12 KW	24 KW	2,9	2,1	3/4" G
FGi110	14 KW	28 KW	2,9	2,1	3/4" G
FGi130	16 KW	36 KW	3,8	2,7	3/4" G
FGi150	21 KW	43 KW	5	3,3	3/4" G

certificazioni
certifications

costruiti ed omologati
secondo le norme
manufactured and certified
according to norms



Misure in cm ±2% • Le caratteristiche e i dati riportati nel presente catalogo possono subire variazioni senza preavviso / • Sizes in centimeters ±2% • Data and features in this catalog may change without notice

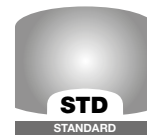
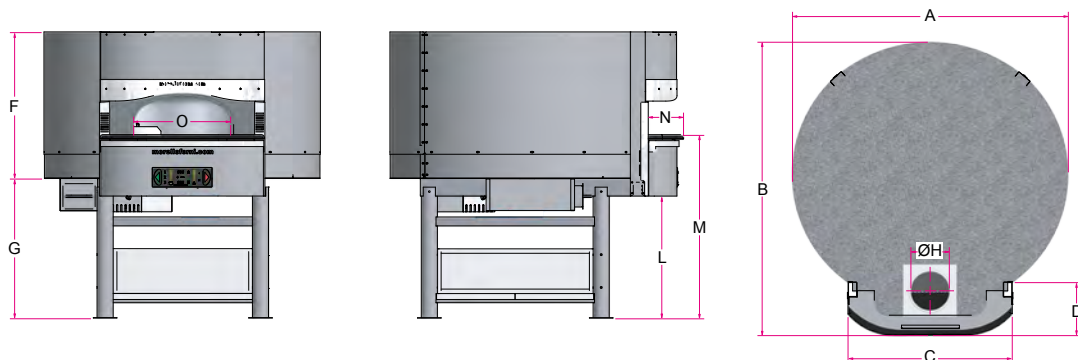

serie

FGi

**Forno ibrido legna e gas
+ piano riscaldato a gas**
*Hybrid wood and gas oven
+ gas heated bedplate*

Mod./Ref.	ØH	A	B	C	D	F	G	L	M	N	O	peso/weight (kg)
FGi100	25	156	167	92	30	100	94	90	122	25	45	1600
FGi110	25	166	177	102	30	100	94	90	122	25	55	1700
FGi130	25	186	196	112	30	100	94	90	122	25	65	2100
FGi150	25	212	212	122	30	100	94	90	122	25	75	2500

**FORNO STATICO/
STATIC OVEN**

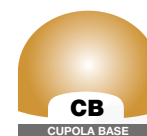
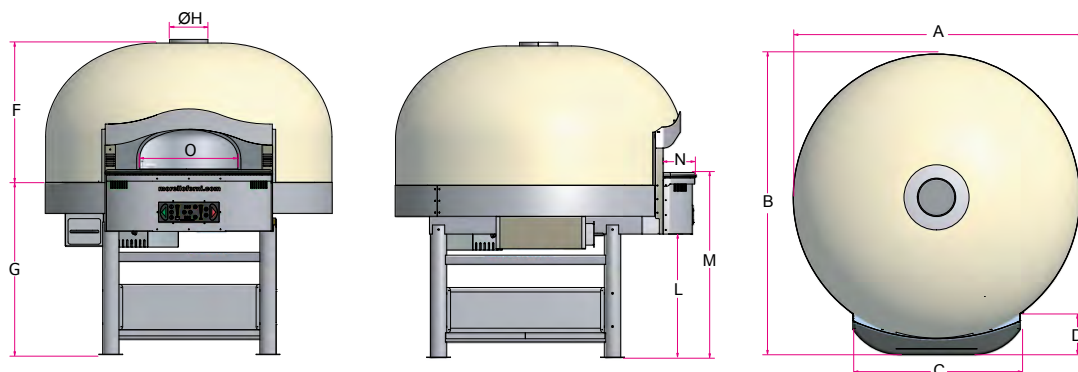

Mod./Ref.	ØH	A	B	C	D	F	G	L	M	N	O	peso/weight (kg)
FGi100	25	162	167	92	30	100	94	90	122	25	45	1700
FGi110	25	166	177	102	30	100	94	90	122	25	55	1800
FGi130	25	186	196	112	30	100	94	90	122	25	65	2200
FGi150	25	212	212	122	30	100	94	90	122	25	75	2700

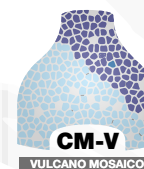
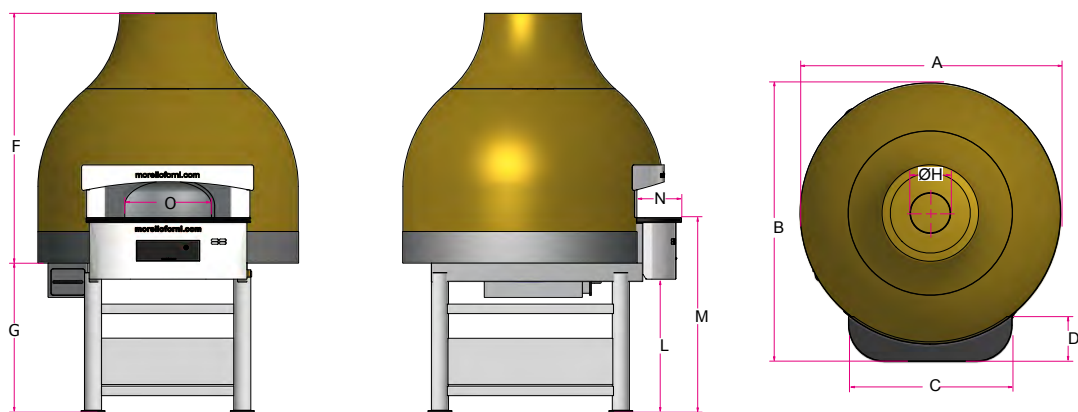

Mod./Ref.	ØH	A	B	C	D	F	G	L	M	N	O	peso/weight (kg)
FGi100	25	162	167	92	30	124	92	90	122	25	45	1900
FGi110	25	166	177	102	30	132	94	90	122	25	55	2000
FGi130	25	190	200	112	30	132	94	90	122	25	65	2400
FGi150	25	212	212	122	30	140	94	90	122	25	75	2900

alcune nostre finiture
some of
our finishes

